

Light
Receptacle

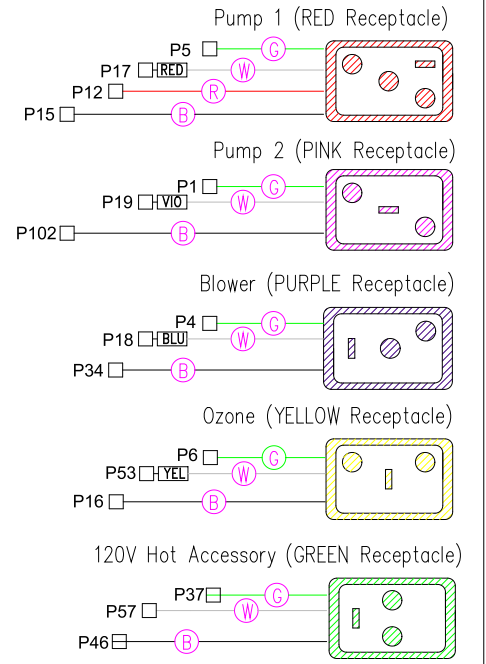
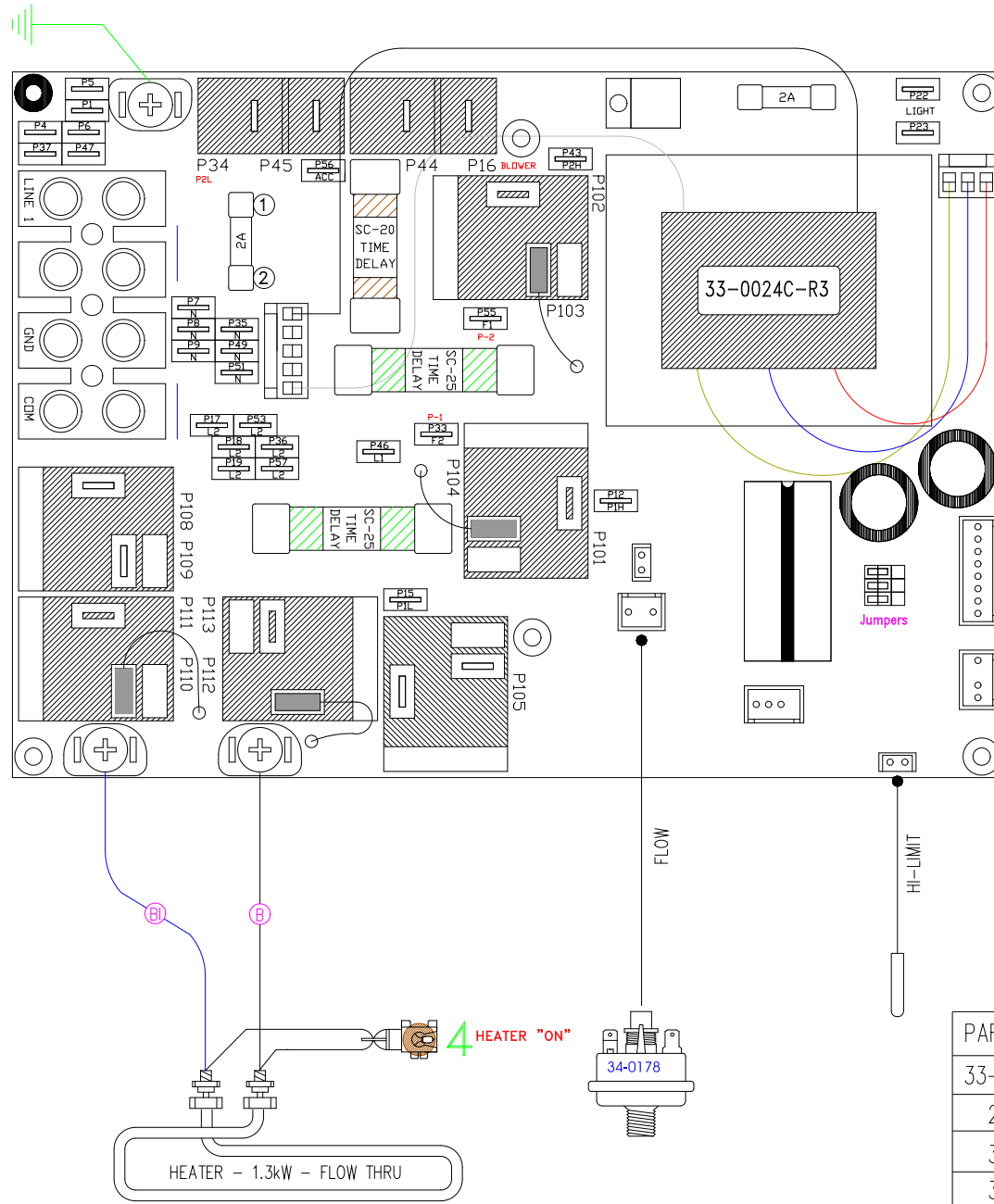
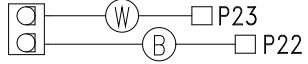

PART NUMBER	DESCRIPTION	QTY
33-0024C-R3	PCB, DIG. ECO-3, 240V	1
26-0071X	HEATER, 1.3kW FLOW THRU	1
34-0178	SWITCH, PRESSURE, 1AMP	1
34-0201D	HIGH LIMIT SENSOR, 18"	1
34-0203D	TEMPERATURE SENSOR, 10FT	1

Manufacture Notes:

System replacement fuse included with each unit (attached to inside faceplate).

Drawn	Rev	Wire Color Code
MBS	1	B - Black Br - Brown R - Red O - Orange Y - Yellow
Date	08.08.07	G - Green Bl - Blue V - Violet W - White Gr - Gray
Diagram No.	8016_SPL	